

TITLE: SPECIFICATION CONTROL DRAWING

PART IDENTIFIER:

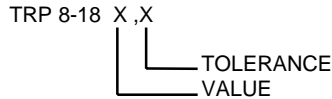

DESCRIPTION: : ROD RESISTOR, BERYLLIA

ASSEMBLY DWG: 1300014

1.0 SPECIFICATIONS:

- 1.1 ELECTRICAL:
 - 1.1.1 RESISTANCE RANGE: 10Ω TO 250Ω.
 - 1.1.2 TOLERANCE: 1%, 2%, OR 5%.
 - 1.1.3 INPUT POWER:
 - 1.1.3.1 IN AIR 125°C: 0.25 WATT.
 - 1.1.3.2 HEAT SINK 100°C: 20 WATTS.
- 1.2 MECHANICAL:
 - 1.2.1 OUTLINE DWG: SEE SHEET 2.
 - 1.2.2 WORKMANSHIP: PER MIL-STD-454, REQUIREMENT 9.
- 1.3 ENVIRONMENTAL:
 - 1.3.1 TEMPERATURE RANGE:
 - 1.3.1.1 NON-OPERATING: -55° C TO +150° C.
 - 1.3.1.2 OPERATING: -55°C TO +125°C.

2.0 UNIT MARKING: NONE

3.0 QUALITY ASSURANCE:

- 3.1 VISUAL INSPECTION:
 - 3.1.1 SAMPLE INSPECT PER ANSI/ASQC Z1.4 GENERAL INSPECTION, LEVEL II, AQL = 1.0.
 - 3.1.2 VISUAL AND MECHANICAL EXAMINATION FOR CONFORMANCE TO CONTROL DRAWING REQUIREMENTS.
- 3.2 100% DCR CHECK:
 - 3.2.1 ACCEPTANCE LIMITS: RESISTANCE VALUES AND TOLERANCE AS SPECIFIED ON PART ROUTING.
- 3.3 SAMPLE DCR CHECK. 5% TOLERANCE ONLY.
 - 3.3.1 SAMPLE INSPECT PER ANSI/ASQC Z1.4 GENERAL INSPECTION, LEVEL II, AQL = 1.0.
 - 3.3.2 ACCEPTANCE LIMITS: RESISTANCE VALUES AND TOLERANCE AS SPECIFIED ON PART ROUTING.

4.0 PACKAGING: STANDARD PACKING PER MC0023.

ENG		PUR		MFG		PLAN		SM		
CC				QA						
EMC TECHNOLOGY, INC 1971 OLD CUTHBERT ROAD CHERRY HILL, NJ 08034		CAGE CODE # 24602					DWG #	1001615000		
		CHANGE NOTICE	EN 01-498				REV LVL	C		
							SHEET	1 OF 2		

PART ID REF

TRP 8-18

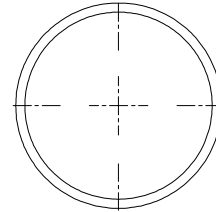
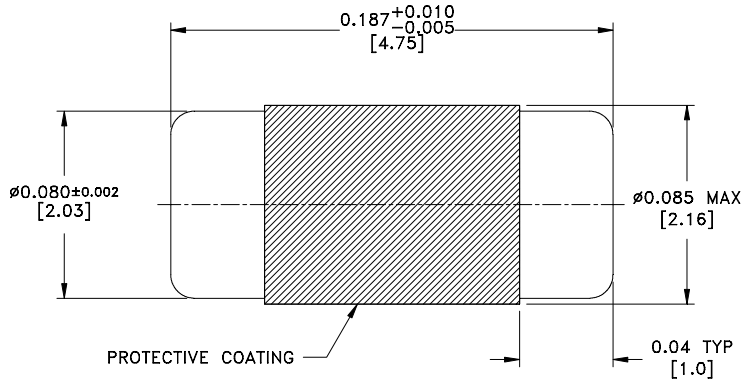

MECHANICAL SPECIFICATIONS:

SUBSTRATE:
 MATERIAL - BERYLLIA 99.5%, ASTM F356.
 TERMINAL:
 MATERIAL - GOLD OVER NICKEL PLATING.

METRIC EQUIVALENTS GIVEN IN [mm]
 FOR REFERENCE INFORMATION ONLY

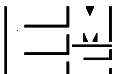

 EMC TECHNOLOGY INC 1971 OLD CUTHBERT RD CHERRY HILL NJ 08034 PHONE NO. (856) 429-7800 FAX NO. (856) 429-1807	UNLESS OTHERWISE SPECIFIED DIMENSIONS ARE IN INCHES TOLERANCES FRACT --- -- ANG --- -- XX ±0.01 XXX ±0.005 XXXX --- --		THESE DRAWINGS AND SPECIFICATIONS ARE THE PROPERTY OF EMC TECHNOLOGY INC AND SHALL NOT BE DUPLICATED OR USED AS BASIS FOR THE MANUFACTURE OR SALE OF PARTS OR DEVICES WITHOUT PERMISSION.					
	CAGE CODE	SCALE	DRAWN BY	CHECKED BY	APPROVED BY			
	24602	1:1	CME 01/09/2002		DAR 1/9/02			
REV	CHANGE NOTICE	DRAWING NO	SHEET					
C	EN 01-498	1001615000	2 OF 2					